



WT-35 BI-DIRECTIONAL REWIND SYSTEM

AAA Press International is an authorized distributor of WEB TECHNIQUES equipment.

The All New WT-35 rewind machine is a PLC controlled bi-directional roll label rewinder with HMI back-lit touch-screen operator interface. The bi-directional rewind feature enables operators to precisely place production waste at the desired position on the table for removal.

- Bi-directional rewinding system, produce high quality rolls in either direction
- Fast, easy to use
- Requires practically no set-up time
- Quickly rewinds large master rolls into rolls of predetermined count or length

 **AAA Press International, Inc.**

3166 N. Kennicott Ave ■ Arlington Heights, IL 60004 ■ www.aaapress.com ■ info@aaapress.com
US & CAN Phone 800.678.7222 | Fax 800.678.7983 ■ INT. Phone +1 847.818.1100 | Fax +1 847.818.0071

Features:

1. BI-DIRECTIONAL SYSTEM

Automatically positions issues for easy identification and repair Allows rolls to be run and counted in either direction and allows rolls to be returned to original copy position in half the time

2. INFINITELY VARIABLE MOTOR SPEED CONTROL

System will automatically “over speed” the motor, rewinding smaller diameter cores twice as fast as the WT-25 rewind system family

3. PEDESTAL MOUNTED HIGH VISIBILITY, BACKLIT TOUCH SCREEN CONTROL

Dual Preset: Set one point for deceleration and a second point for final stop Counts in both English or Metric Units at the touch of a button

4. WIND LABELS IN OR OUT

5. PNEUMATIC FRICTION BRAKE FOR MORE ACCURATE AND REPEATABLE TENSION CONTROL

6. STAINLESS STEEL REWIND SURFACE

Easily add options in the field utilizing the extruded aluminum frame

8. CONSTANT SPEED CONTROL

Allows system to automatically maintain desired web speed

9. MISSING LABEL DETECTION

10. UNREMOVED MATRIX DETECTION

11. CHOICE OF COREHOLDER STYLES

Lift-Off Cam-Lock (Mechanical); Lift-Off Air Inflatable (Great choice for quickly switching between coreholder sizes); Flange Mounted Air Inflatable

12. CHOICE OF COREHOLDER SIZES

Coreholders range in size from coreless to 0.4” through 6” (25mm through 120mm), Please do not hesitate to contact us with any special requests

13. CHOICE OF COUNTING SYSTEMS

Our systems are compatible with almost any counting system available, Please do not hesitate to contact us with any special requests

Optional:

1. BAR CODE VALIDATION SYSTEM

2. DATA LOGGING SYSTEM

3. SPLICE DETECTION SYSTEM

4. COMPRESSED AIR MODULE

Allows WT-35 system to be operated in locations with no compressed air availability

5. SURGE PROTECTION/BATTERY BACK-UP

Protects system from power issues and allows for up to 45 minutes of run time during a power loss

6. RAZOR BLADE SLITTING ATTACHMENT

Requires air coreholder on the rewind for multiple cores

7. STROBE SYSTEM

Light flashes with each label to provide a “Stand Still” effect for visual inspection of the labels on a moving web

8. ERGO-LIFT HEIGHT ADJUSTMENT SYSTEM

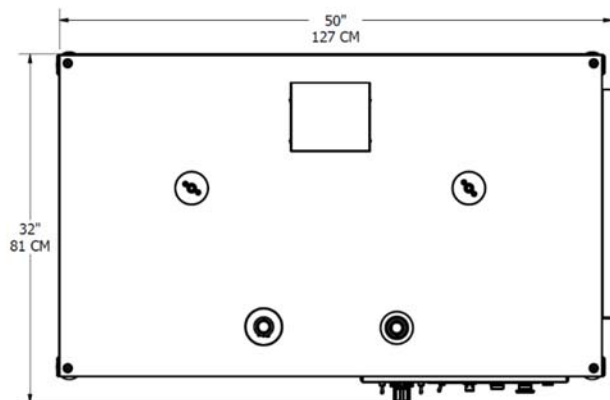
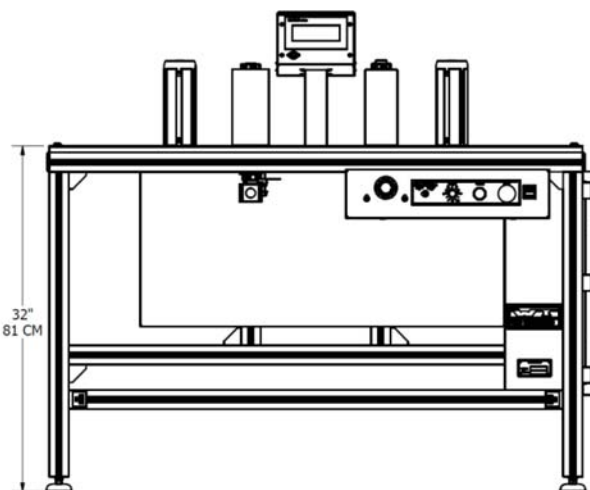

 **AAA Press International, Inc.**

3166 N. Kennicott Ave ■ Arlington Heights, IL 60004 ■ www.aaapress.com ■ info@aaapress.com
US & CAN Phone 800.678.7222 | Fax 800.678.7983 ■ INT. Phone +1 847.818.1100 | Fax +1 847.818.0071