

WT-30LCI REWIND SYSTEM

AAA Press International is an authorized distributor of WEB TECHNIQUES equipment.

SAVE TIME & MONEY WITH A WEB TECHNIQUES REWIND SYSTEM.

Improve your production capacity by quickly and accurately inspecting, counting and rewinding labels; finished and ready for shipment.

- Fast & easy to use
- Requires virtually 0 set-up time
- Quickly rewinds large master rolls into rolls of predetermined count or length
- Accurate built-in photoelectric counting system



AAA Press International, Inc.

3166 N. Kennicott Ave ■ Arlington Heights, IL 60004 ■ www.aaapress.com ■ info@aaapress.com
US & CAN Phone 800.678.7222 | Fax 800.678.7983 ■ INT. Phone +1 847.818.1100 | Fax +1 847.818.0071

Features:

1. INFINITELY VARIABLE MOTOR SPEED CONTROL

System will automatically “over speed” the motor, rewinding smaller diameter cores twice as fast as the WT-25 rewind system family

2. PEDESTAL MOUNTED HIGH VISIBILITY, BACKLIT TOUCH SCREEN CONTROL

Dual Preset: Set one point for deceleration and a second point for final stop Counts in both English or Metric Units at the touch of a button

3. WIND LABELS IN OR OUT

4. STAINLESS STEEL REWIND SURFACE

5. CONSTANT SPEED CONTROL

Allows system to automatically maintain desired web speed

6. MISSING LABEL DETECTION

7. UNREMOVED MATRIX DETECTION

8. CHOICE OF COREHOLDER STYLES

Lift-Off Cam-Lock (Mechanical); Lift-Off Air Inflatable (Great choice for quickly switching between coreholder sizes); Flange Mounted Air Inflatable

9. CHOICE OF COREHOLDER SIZES

Coreholders range in size from coreless to 0.4” through 6” (25mm through 120mm), Please do not hesitate to contact us with any special requests

10. CHOICE OF COUNTING SYSTEMS

Our systems are compatible with almost any counting system available, Please do not hesitate to contact us with any special requests

Optional:

1. BAR CODE VALIDATION SYSTEM

2. DATA LOGGING SYSTEM

3. SPLICE DETECTION SYSTEM

4. COMPRESSED AIR MODULE

Allows WT-35 system to be operated in locations with no compressed air availability

5. SURGE PROTECTION/BATTERY BACK-UP

Protects system from power issues and allows for up to 45 minutes of run time during a power loss

6. RAZOR BLADE SLITTING ATTACHMENT

Requires air coreholder on the rewind for multiple cores

7. STROBE SYSTEM

Light flashes with each label to provide a “Stand Still” effect for visual inspection of the labels on a moving web

8. ERGO-LIFT HEIGHT ADJUSTMENT SYSTEM

9. STATIC ELIMINATION SYSTEM (de-ionizing system)

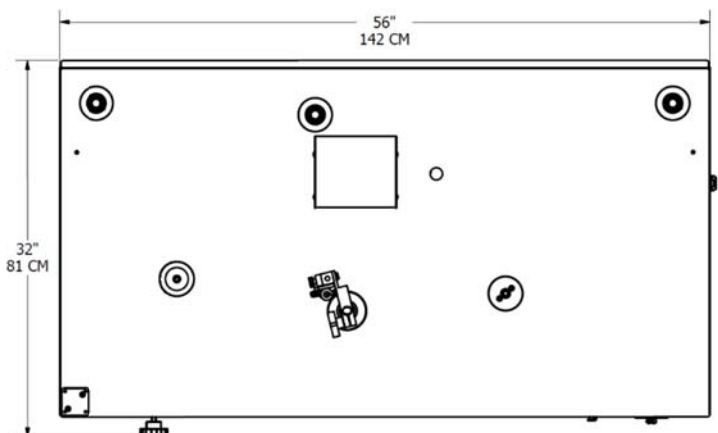
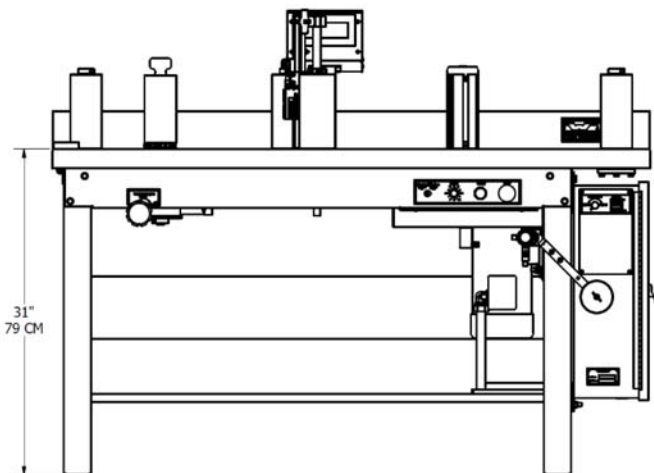

 **AAA Press International, Inc.**

3166 N. Kennicott Ave ■ Arlington Heights, IL 60004 ■ www.aaapress.com ■ info@aaapress.com
US & CAN Phone 800.678.7222 | Fax 800.678.7983 ■ INT. Phone +1 847.818.1100 | Fax +1 847.818.0071